



FEEDER HOUSE SPROCKET
MANUAL
WI89





colliermiller.com.au



Collier & Miller Pty Ltd
43 Jondaryan Ave Griffith NSW 2680 Australia
P: +61 2 6969 4500
E: sales@colliermiller.com.au

TABLE OF CONTENTS

W189 Feeder House Sprocket Manual

General Information	Page
INTENDED USE	2
Fitment Guide	3
Installation	
SPROCKET KIT INSTALLATION INFORMATION	4
FEEDER CONVEYOR DRIVE GEARBOX – ALIGNMENT	5
FEEDER DRIVE SYSTEM INSTALL – TOP SHAFT	8
Components	11
Warranty	
CONSUMER GUARANTEE	12
WARRANTY	13
WARRANTY EXCLUSIONS	14
Notes	15

GENERAL INFORMATION

WI89 Feeder House Sprocket Manual

INTENDED USE

The Collier & Miller WI89 Feeder House Sprocket Assembly is designed to be fitted to specific model Case-IH® combine harvesters for the purpose of driving the Feeder House Chain Assembly. This sprocket assembly is specifically intended for use in machines where the feeder house is not equipped with a rock trap. It provides a direct and reliable drive solution, serving as a replacement component for the original Case-IH® sprocket—excluding applications involving a radial pin clutch.

Designed and manufactured by Collier & Miller.

The WI89 Feeder House Sprocket is a component assembly with the design purpose to:

- Drive the feeder house chain on specific Case-IH® combine harvester models
- Be fitted as a direct replacement for the original Case-IH® sprocket (excluding radial pin clutch variants)
- Be used in machines where the feeder house is not equipped with a rock trap
- Deliver reliable performance in harvesting operations requiring consistent chain drive engagement

The purpose of this manual is to give the user a complete understanding of the following:

- Fitment Guide
- Installation
- Kit Components

FITMENT GUIDE

WI89 Feeder House Sprocket Manual

Case-IH® Compatible

Flagship 120, 230 & 240 Series

SERIES	MODELS	PART NUMBER
Case-IH® 120 Series	7120, 8120, 9120	86773520
Case-IH® 230 Series	7230, 8230, 9230	84414906
Case-IH® 240 Series	7240, 8240, 9240	84414906

Case-IH® Compatible ensures the C&M aftermarket part will fit the machine model stated based on our research and customer feedback. C&M parts are an aftermarket product and do not make a claim to be a genuine Case-IH® part. It is recommended prior to ordering you should verify the parts will fit your equipment. Case-IH® is a registered trademark of CNH Industrial America LLC.

INSTALLATION

WI89 Feeder House Sprocket Manual

SPROCKET KIT INSTALLATION INFORMATION

This installation section includes information sourced from the original Case-IH® installation documentation. Portions of that content are reproduced here to assist installers in following best practice during the installation and commissioning of the WI89 Sprocket Assembly. All intellectual property remains the property of Case-IH® and is included solely for reference and guidance.

 **WARNING:** The service life of the sprocket drive spline and hub is highly dependent on correct installation. Proper alignment of the gearbox output shaft, in accordance with Case-IH® recommendations, is essential to ensure optimal performance and longevity.

 **WARNING:** Misalignment between the gearbox and the feeder chain top sprocket—either during installation or operation—can result in accelerated wear of the splined hub and shaft. Any wear resulting from misalignment will be considered normal wear and tear or an installation/operation issue and is therefore not covered under warranty.

INSTALLATION

W189 Feeder House Sprocket Manual

FEEDER CONVEYOR DRIVE GEARBOX – ALIGNMENT

NOTE:

Output shaft (A) is the only gearbox output shaft on feeders without the rock trap.

Output shafts (A) and (B) are present on feeders with the rock trap.

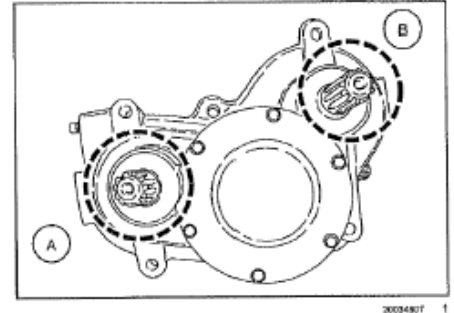

1. Prepare the proper thickness of shims to be placed between the gearbox and the feeder house frame to align the output shaft.

NOTICE:

The arrangement shown in image 2 is recommended starting point, it may need to be adjusted accordingly to the outcome in step 12.

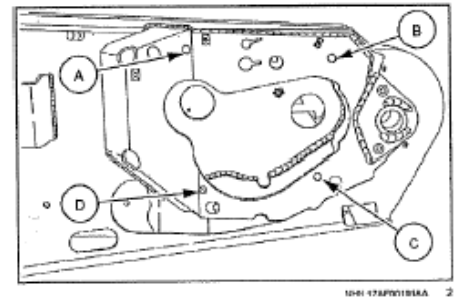

- (A) 0 mm
- (B) 3mm
- (C) 5mm
- (D) 5mm
4mm (if needed)

Part Number

- 86511326
- 86639326
- 86639326
- 394631

INSTALLATION

W189 Feeder House Sprocket Manual

FEEDER CONVEYOR DRIVE GEARBOX – ALIGNMENT (CONTINUED)

2. Obtain the two M16 x 150mm bolts used to remove the gearbox earlier and install in the two upper holes (B)
3. Attach a hoist with a strap to the two bolt holes installed in step 2 and/or use an assistant to move the feeder gearbox to the feeder house.

NOTE: If machine is equipped with rock trap beater, ensure rock trap beater is guided onto output shaft of the feeder gearbox.

4. Install the two M16 x 60mm lower bolts, washers and appropriate shims at (A).
5. Remove the two bolts installed in step 2 and install the two upper M16 x 60mm bolts, lock washers and shims at (B).

NOTE: Retain the two M16 x 150mm bolts removed in step 5

6. Torque the upper and lower bolts to:
174-220Nm (132-161 In ft)

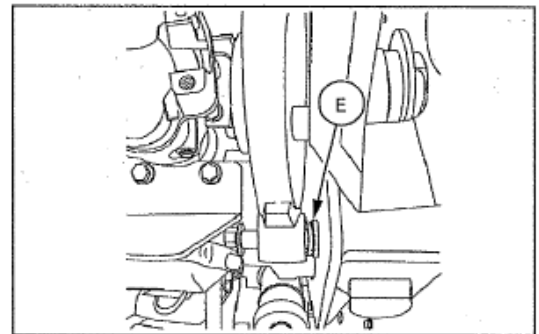
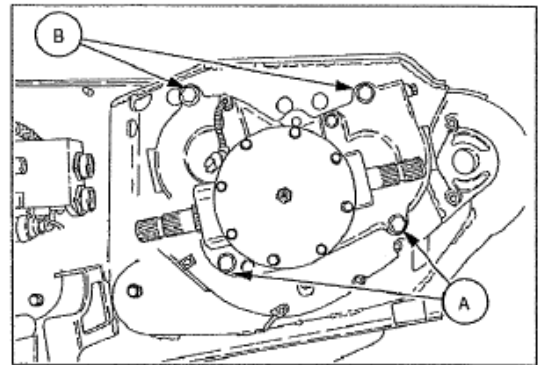

NOTE: The laser, laser adaptor and target mentioned in steps 7,8 and 9 may be obtained as a kit from CNH, 380003354B

7. Attach the laser adaptor **3800003354-5 (A)** to the end of the shaft that drives the top sprocket
8. Insert laser (B) into the laser adaptor

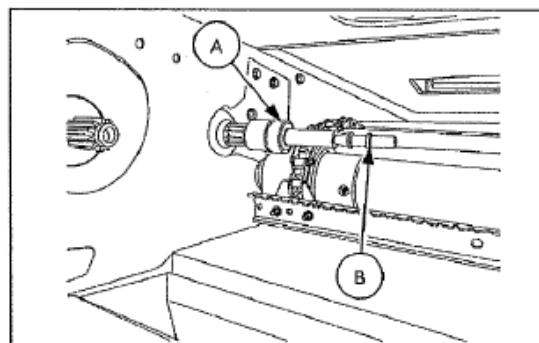

INSTALLATION

W189 Feeder House Sprocket Manual

FEEDER CONVEYOR DRIVE GEARBOX – ALIGNMENT (CONTINUED)

9. Provide a target for the laser by installing 3800003354-6 (C.) over the welded bolts in the right hand side of the feeder housing

NOTE: You may procure a target locally instead of using 380003354-6

10. Determine the center of the target, and mark it with a marker, white is preferred.
11. Turn on the laser and note where the light hits the right hand side target.
12. The mark created in step 10 and the spot where the laser hits the target should be spaced no more than 6mm apart, otherwise the gearbox shims need to be adjusted, as directed in step 13

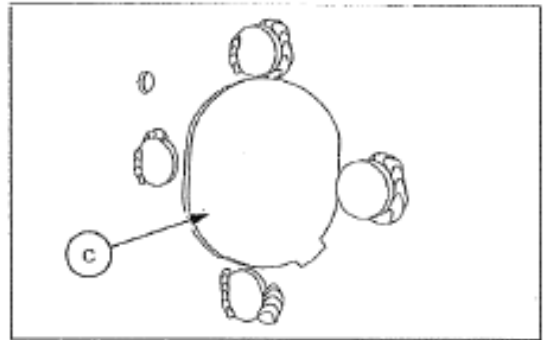

13. Adjusting the gearbox shims:

- A. If the laser light mark is shifted to the right of the center mark, shims must be added to the left mounting points (L)
- B. If the laser light is shifted to the left of the center mark, shims must be added to the right mounting points (R.)
- C. If the laser light mark is shifted above the center mark, shims must be added to the bottom mounting points (B)
- D. If the laser light mark is shifted below the center mark, shims must be added to the top mounting points (T)

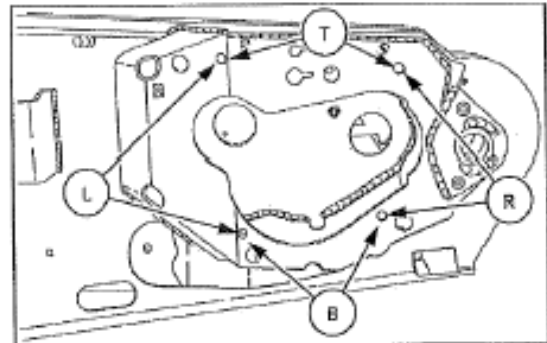

14. If required after adjusting the shims as directed in step 13, repeat steps 11 and 12 until the center mark and laser align within 6mm
15. Obtain a hoist and lift strap and secure gearbox
16. Loosen and remove hardware installed in step 4, replacing the two upper bolts with the two M16 x 150mm bolts removed in 5 and remove gearbox, carefully retaining shims and noting their position.

INSTALLATION

WI89 Feeder House Sprocket Manual

FEEDER DRIVE SYSTEM INSTALL – TOP SHAFT

1. Apply good quality molybdenum disulphide based NLGI #2 grease through the grease nipple located at (NR) in the Top shaft (1) until you see grease entering the spline hub cavity

NOTE: Step 1 ensures that any empty areas inside the top shaft are filled with grease prior to gearbox installation

NOTE: In original CASE top shaft uses felt to seal the drive hub/spline cavity. The C&M WI89 has an integrated rod wiper fitted as an integral part of the top shaft/sprocket. CNH provide steps 2 & 3 in their installation manual to explain how to fit the felt seal, this is not required when installing the C&M WI89.

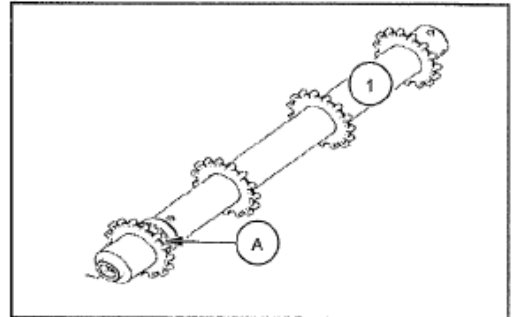

23110106 1

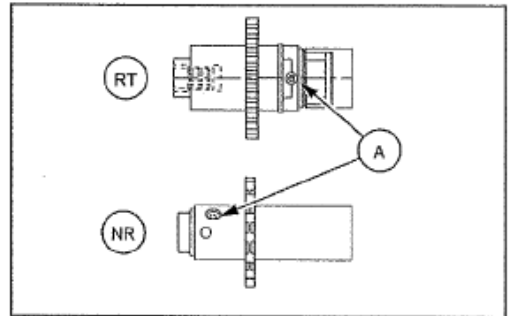

NHL17AF0274AA 2

RT = With Rock Trap
NR = Without Rock Trap

The WI89 is designed to replace the original Case sprocket fitted to feeder houses with-out a rock trap.

INSTALLATION

WI89 Feeder House Sprocket Manual

FEEDER DRIVE SYSTEM INSTALL – TOP SHAFT (CONTINUED)

2. Install the felt seal (5) over the gearbox output shaft (D).

NOTE: This step is not required for the WI89 as the seal is part of the top shaft.

3. Start to install the top shaft over the gearbox output shaft and then push the felt seal in, ensuring that the splines of the felt seal align with the splines on the inside of the top shaft.

NOTE: This step is not required for the WI89 as the seal is part of the top shaft.

4. Install the Top Shaft (1) into the feeder with the threaded end towards the right-hand side. Install materials to support the ends of the sprocket drive shaft.

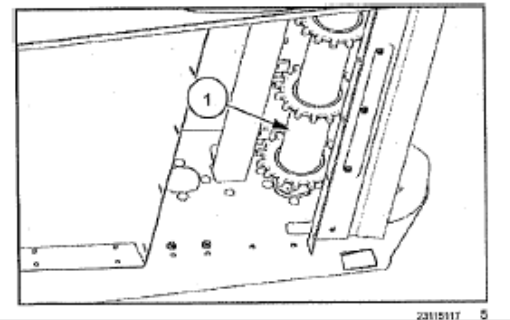
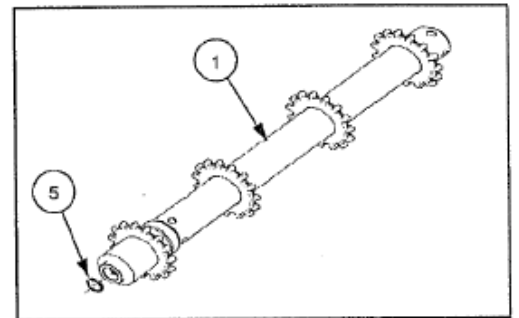
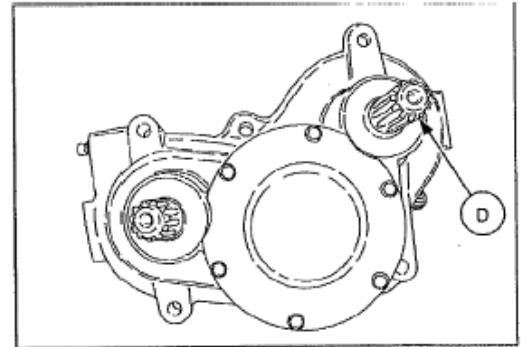

INSTALLATION

W189 Feeder House Sprocket Manual

FEEDER DRIVE SYSTEM INSTALL – TOP SHAFT CONTINUED..

NOTE: In Image 6 and 7 a non rock-trap machine is shown. On a rock trap equipped machine, the top shaft is mounted in the forward mounting position.

5. Engage the bearing assembly (A) into the top shaft and tighten the nuts. Install the 1-1/2" in bolt (B) and washer into the end of the drive shaft.
6. Block the top shaft sprocket with wood to prevent the shaft from rotation while you tighten bolt (B)
7. Torque the 1-1/2" in bolt to 1054-1326 Nm (775-975 In ft)
8. Install dust cap (A)

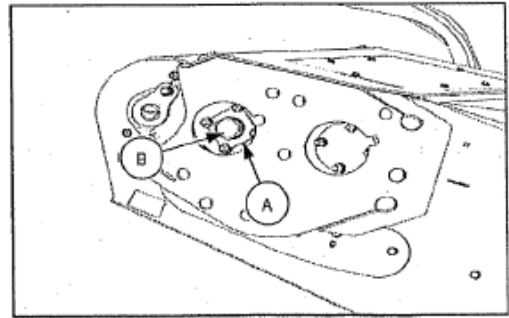

23115113 6

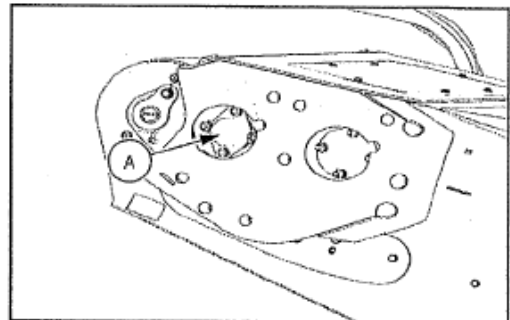

23115112 7

COMPONENTS

WI89 Feeder House Sprocket Manual

If you have purchased the WI89 as a standalone component (not as part of a kit), it will only include the wiper seal and grease nipple. Refer to the table below for a full list of components included in the complete kit.

WI89KIT Includes

ITEM	CASE PN	C&M PN
Complete sprocket	84296465	WI89
Feeder Sprocket RH side bearing (no housing)	86995212	1108KRRB
Gearbox Feed Conveyor Shaft	87282003	CM87282003
Gearbox Feed Conveyor Shaft Bearing	301164	6208DDUC3
Gearbox Feed Conveyor Shaft Seal	87612665	M40X80
Wiper Seal		
Grease Nipple		

WARRANTY

W189 Feeder House Sprocket Manual

CONSUMER GUARANTEE

In accordance with the Australian Consumer Law (ACL), Collier & Miller guarantees that, at the time of delivery, the purchased unit will be of acceptable and high quality. This includes being free from defects in all parts and components, having no hidden workmanship errors, and being safe for use. The unit will also be capable of performing any application for which it was designed and specified, and it will match the description provided at the time of purchase.

If the unit fails to meet this guarantee, Collier & Miller will take all necessary steps to remedy or repair the issue within a reasonable timeframe and at no cost to the customer.

Collier & Miller will also take reasonable steps to source or provide spare parts and repair facilities for the unit for a reasonable period after purchase.

WARRANTY

W189 Feeder House Sprocket Manual

MANUFACTURER'S WARRANTY

Collier & Miller provides this warranty in compliance with the Australian Consumer Law. This warranty offers additional benefits and does not limit or replace your rights under the Australian Consumer Guarantee.

All components of new Collier & Miller equipment are covered under a **12-month warranty** from the date of delivery to the customer. Under this warranty, Collier & Miller will repair or replace any defective part or component, including any workmanship errors. Any replacement parts or components will carry a warranty period equal to the remainder of the original unit's warranty.

If a part or component is faulty or defective, stop using the unit immediately and contact Collier & Miller as soon as practically possible.

For warranty claims, Collier & Miller can be contacted via:

Phone: Monday to Friday, 7:00 AM – 5:00 PM, and Saturday, 7:30 AM – 12:00 PM at 02 6969 4500

Email: sales@colliermiller.com.au

Once the claim is assessed and accepted, the customer will be notified within a reasonable timeframe regarding the next steps.

If a part or component requires replacement, Collier & Miller will arrange and cover the cost of sending the replacement to the customer within a reasonable timeframe.

If a part or component requires repairs, the customer is responsible for returning it to Collier & Miller at their own cost. Once the repair is complete, Collier & Miller will cover the cost of returning the repaired part to the customer.

WARRANTY

W189 Feeder House Sprocket Manual

WARRANTY EXCLUSIONS

 **WARNING:** The service life of the sprocket drive spline and hub is highly dependent on correct installation. Proper alignment of the gearbox output shaft, in accordance with Case-IH® recommendations, is essential to ensure optimal performance and longevity.

 **WARNING:** Misalignment between the gearbox and the feeder chain top sprocket—either during installation or operation—can result in accelerated wear of the splined hub and shaft. Any wear resulting from misalignment will be considered normal wear and tear or an installation/operation issue and is therefore not covered under warranty.



colliermiller.com.au

Collier & Miller Pty Ltd
43 Jondaryan Ave Griffith NSW 2680 Australia
P: +61 2 6969 4500
E: sales@colliermiller.com.au